

MAC

METAL ARCHITECTURAL



Installation guide

HARRYWOOD



CAUTION:

The material may have sharp edges. We recommend using protection equipment, including safety boots, helmet, goggles and gloves.



WARRANTY

FOR THE WARRANTY TO BE APPLICABLE, INSTALLATION MUST BE CARRIED OUT IN ACCORDANCE WITH THE STANDARDS SET OUT IN THE UPDATED BUILDING CODE, ALONG WITH THE MANUFACTURER'S RECOMMENDATIONS.

In the event that a problem occurs during the installation of the profiles. It's important to notify the supplier before the installation of 144p2 (2 boxes), to make sure that the warranty will apply. Over 144 sq. Ft. The responsibility for the installation goes to the installer.

INSPECTION

When you receive your order, it is important to inspect the product immediately. If there are any issues with your order or if panels arrive damaged, you should inform your supplier as soon as possible.

HANDLING

Handle the box with care, ensuring to move it only vertically.

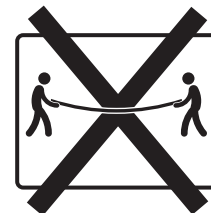

WOOD COLLECTION

The Harrywood collection includes six planks with varying grains and nuances. Please ensure that the planks are installed in random order. Each plank is stamped on the reverse side with a 1 to 6 digit sequence in bold character preceded with the pound sign. If you pay particular attention to this when installing the siding, you will undoubtedly optimize the look of your project. In addition, do not put the number of boards 1 to 6 in order. It is recommended to mix the sequences randomly to obtain an optimal result.

*Please note that the boxes come pre-mixed and that each contains twelve 12' planks, for a total of 72 sq. ft.

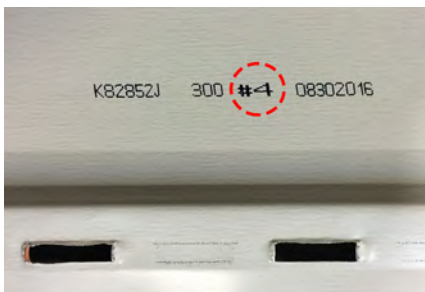

STORAGE

To keep the esthetic and physical properties of MAC Metal Architectural's HARRYWOOD metal siding intact, it is important to follow some basic rules for storage.

If the panels cannot be installed immediately upon delivery, store them indoors in a dry, well-ventilated area. Customers are responsible for risks involved with storing panels outdoors. However, if the material must be stored outside, here are a few recommendations:

Place the panels in an area with no direct exposure to the sun or to extreme temperatures, as these factors may cause the protective coating to further adhere to the panels. This can make the coating more difficult to remove, and leave glue marks on the panels.

We also recommend using a tarp to protect the materials from temperature fluctuations.

1. TOOLS

To complete the work correctly, you will require a MAC cutter, a MAC metal folder or a pair of folding tongs, a drill, and a pair of sheet cutters. You will also need a level, a tape measure and safety goggles. MAC Metal Architectural equipment is available at the MAC supplier nearest you.

The screws must conform to ASTM B117-2000h. The use of Century MAC screws designed for these profiles is highly recommended by the manufacturer.

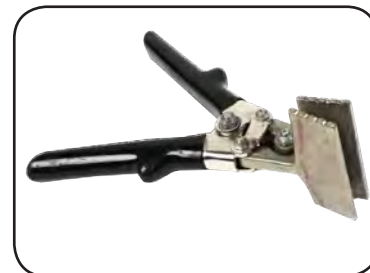
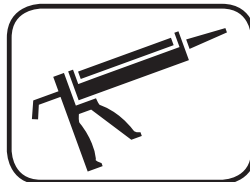
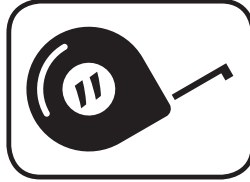
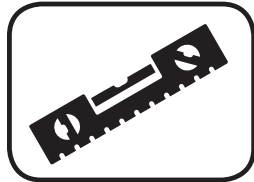

2. ACCESSORIES

Here is a list of accessories required to install and finish Harrywood siding:

- MAC wood screws or metal screws, depending on the type of project
- MAC waterproof membrane
- Adhesive elastomeric membrane
- Steel roll*
- Mouldings
- Anti-intrusion grid

*Steel rolls can be provided for finishing work

PANEL FEATURES

- A. There is a memory foam in the back
- B. 0.16"-wide screw rail along the entire length of the structure
- C. 3/4" holes for screws, with 2.36" between each hole (center to center).

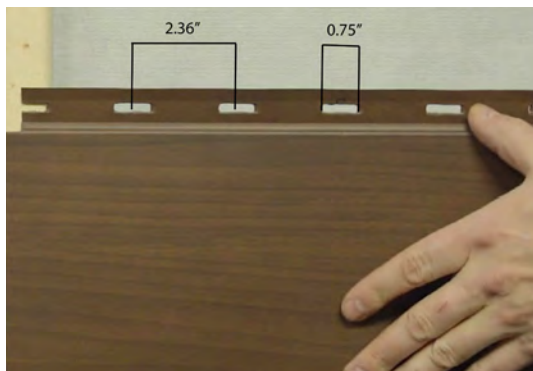

HARRYWOOD TRIM & FLASHING

M20C
Outside corner

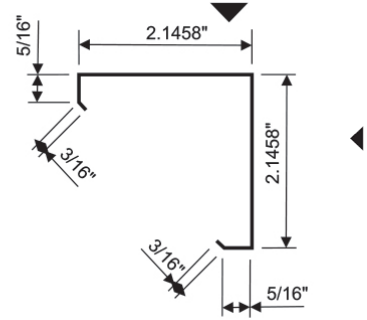
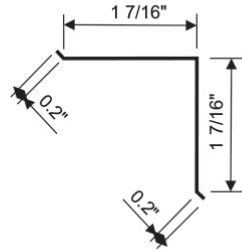
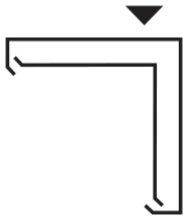

1402
Starter strip

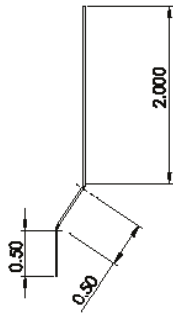

M50C
Base flashing

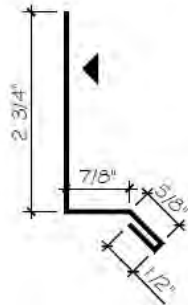

M53CD
Base flashing

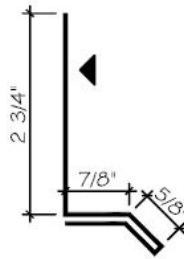

M56C
Base flashing

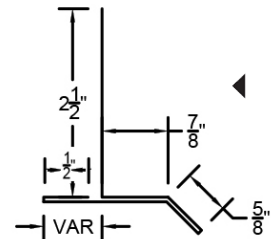

M22C
QJ Trim inside corner

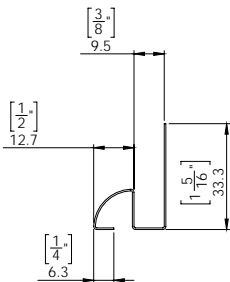

M14C
Double L Trim

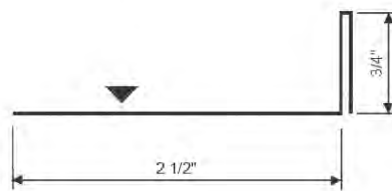

M01C
J Trim

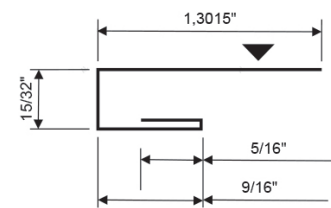

M03C
Extended 2 piece J Trim

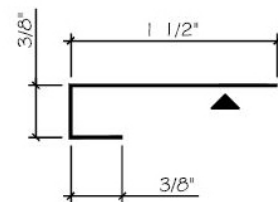
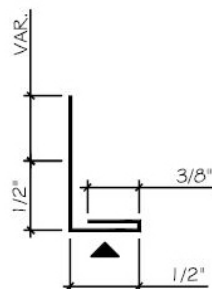
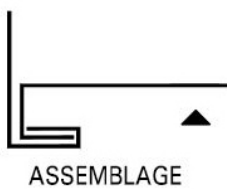

HARRYWOOD TRIM & FLASHING

M12C
Transition molding

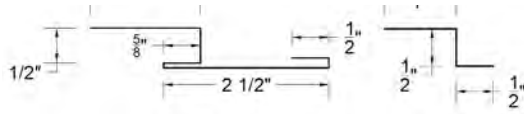

M13C
Transition joint

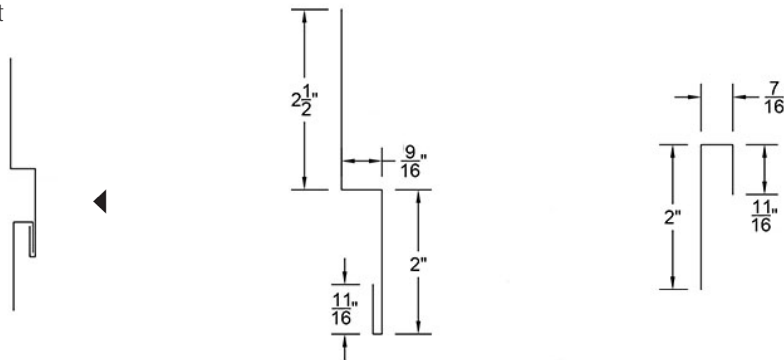

3. PREPARATION

Before beginning the first step, ensure that the construction of the surface to be covered with Harrywood siding complies with all current industry standards.

Please check with your local authorities regarding the installation of metal or wood furring. If they are not needed, then it's okay not to install them.

Also, make sure to refer yourself to building code of your province.

4. INSTALLATION

Before beginning to install the siding, ensure that your walls are square and level.

Harrywood wall siding can be installed horizontally, vertically or diagonally.

4.1 Starter Strips

Using a laser-guided level, a chalk tracer or a standard level, trace a reference line as a guide to insure the starter strip is in place.



Now, fix the M10SHW starter strips 3" above where you want your wall to begin. Use MAC 1/2" flathead metal screws or MAC 1 1/8" flathead wood screws. Secure the strip using one screw. When you'll be level, screw it in place.

**Ensure that the starter strip is level, as it will serve as a guide for the rest of the installation.



4.2 Screws

Tighten screws by applying moderate pressure to the metal to allow expansion. Screws should not be placed under upward or downward pressure to avoid deforming the siding and/or opening the joints.

*Screws should be installed every 16" in the middle of the pre-cut holes, to allow expansion.



Metal screw



Wood screw



If a section of furring strip appears not to be aligned, we recommend leaving some space between the wall and the furring strip of the metal siding once the screw has been inserted. This will avoid placing too much pressure on the product, which can cause an undesired effect.

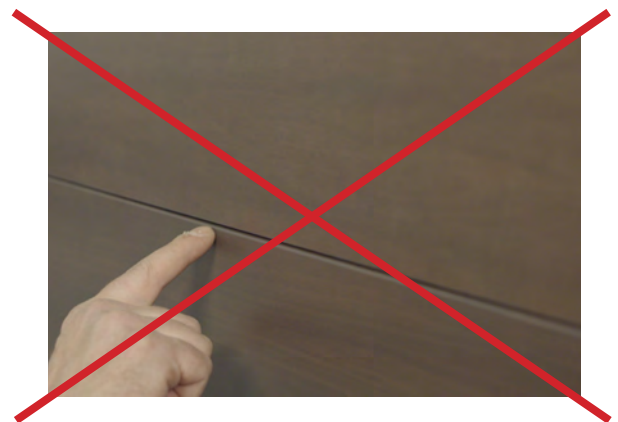

4.3 Plastic membrane

Wherever possible, only remove the plastic membrane once the installation is done.



4.4 Cutting

If you need to cut the panels, use the specialized MAC (SX14) cutter for Harrywood siding, recommended by MAC Metal Architectural. You can also use if needed a snip or a shear.

*The using of an electric saw is **not recommended** or cover by MAC Metal Architectural.



4.5 Joints

Only factory cuts should be used for wall joints and cutting onsite should only be done for wall mouldings.



4.6 Expansion

When joining the panels along their length, a space must be left for the dilation and expansion of the material, depending on the temperature during installation. A 1/16" space should be left between planks and 1/8" for mouldings. For buildings made of new wood and with more than one story, an expansion joint should be used on the main floor. Moulding #1415 should also be used for edging between the two materials.

5. INSIDE CORNER

5.1 L steel corner

Place an L-shaped steel corner or adhesive elastomeric membrane directly on the weather-stripping or furring strip.

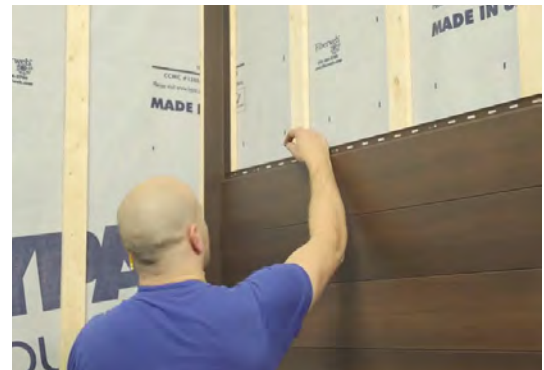

5.2 QJ Trim inside corner

Continue cladding the siding on one of the walls, and attach the QJ corner mouldings for inside corners (#1407). Continue installing siding on the other wall, while ensuring to slide the planks right to the end of the QJ inside-corner mouldings.

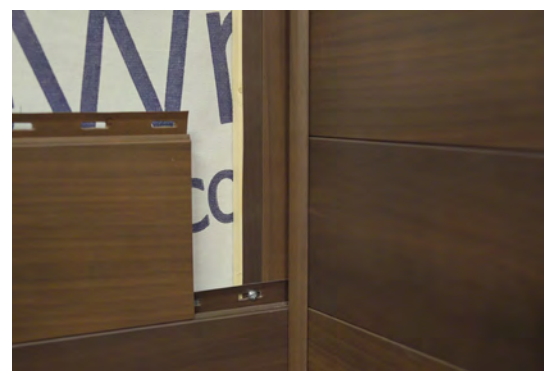

6. OUTSIDE CORNER

Outside moulding corner #1401 should be installed in two steps:

6.1 Step 1, Corner moulding

After completing the installation of the siding on two adjacent walls, fix the mouldings in place using screws.



6.2 Step 2. Finished trim

Randomly apply drops of MAC sealant inside the trim mouldings before stapling them in place. Apply a 1" W x ¼" H strips of MAC sealant at 24" intervals along the trim.



**If you do not have an anchor point, you must secure the corner with a screw, then trim and fold back the bottom of the trim moulding to create a surface area to hold it in place.

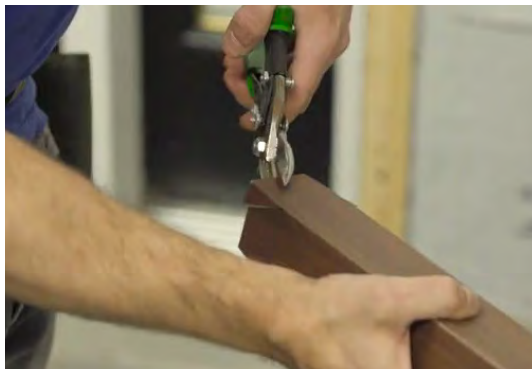

7. WINDOW FRAMING

7.1 Adjustment

Measure and adjust the plank appropriately before attaching it.

If the board does not come flush with the height of the wall, cut it an extra ½" of space in order to fold it at a 45 degree angle. Then set the extra piece backwards to add support, and staple the folded sheet onto the extra piece.



7.2 Step 2. Soffite J Trim installation

If the wall that you are cladding has a window, start by installing a J moulding #1410 around the three sides of the window. Then install a drip cap over the top of the window frame.

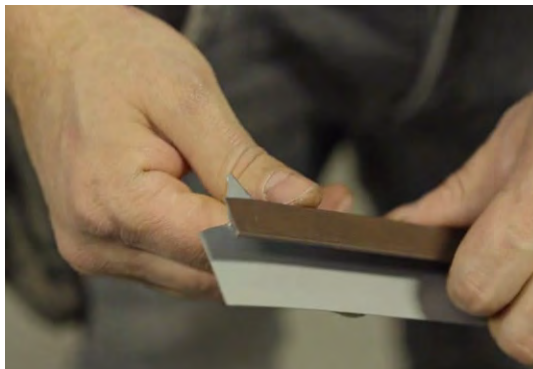

7. WINDOW FRAMING

7.3 Around the window

Continue installing the siding around the sides of the window, while ensuring to place planks with different numbers in random order.



7.4 The top of the window

You must install a drip cap before placing the first plank above the window.

If the plank does not come flush with the height of the wall, cut it with an extra $\frac{1}{2}$ " of material in order to fold it at a 45 degree angle. Then set the extra piece backwards to add support, and staple the folded sheet onto the extra piece.

As shown in section 7.2.



7. WINDOW FRAMING

7.5 The top of the window



8. WALL TERMINATION

8.1 Adjustment

Measure and adjust the final plank accordingly, using an electric shear, before attaching it to the J moulding.



If the plank doesn't come flush with the height of the wall, place the extra piece backwards onto the J moulding to add support to the plank that was cut.



8.2 Soffit J-Trim

Install a soffit J-Trim moulding at the top of the wall.



8. REAR RETAINING BRACKET

8.1 Adjustment

The new Harrywood rear retaining bracket is designed especially for large area installation. Where she acts as a support additional reinforcement from tightening the joints. Easy to install you just insert it on the top of the two boards in the middle of the joint.

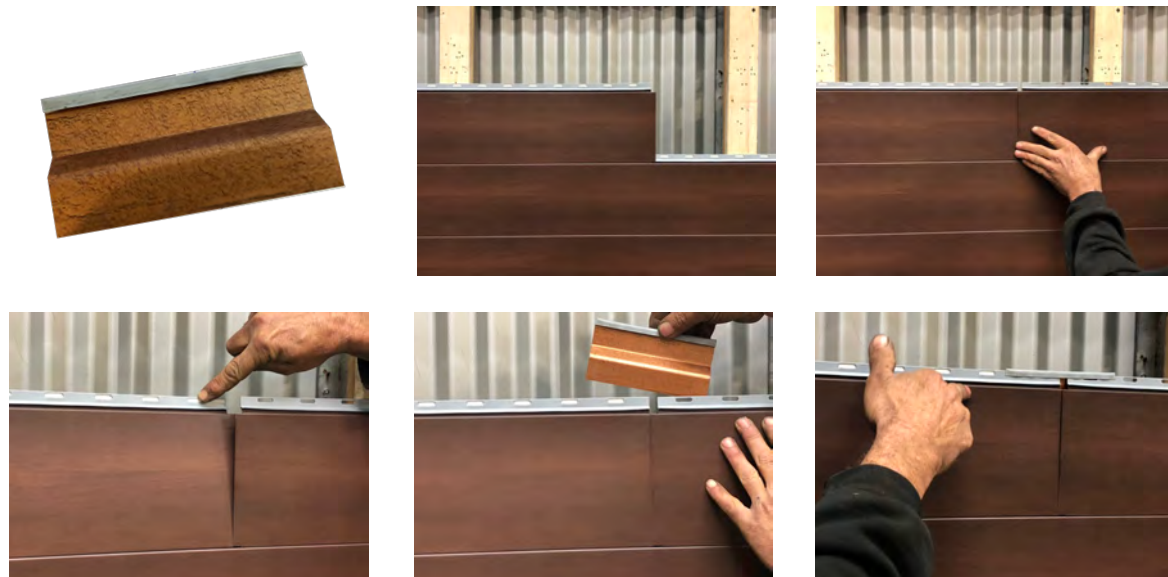

9. REPLACING PLANKS

It is entirely possible to replace planks, We suggest taking a moment to view the related video under the "Sidings" section of our website, at the bottom of the page onHarrywoodsiding.

For more information on the installation of MAC Metal Architectural
MHarrywood, go to MACmetalarchitectural.com for
all installation videos
or contact us directly at 450-464-5486



MAC

METAL ARCHITECTURAL

MAC Metal Architectural Inc.
942, Bernard-Pilon, McMasterville (Quebec) J3G 1L6
T. 450-464-5486 | TF. 888-464-5486 | F. 450-464-4538
info@macmetalarchitectural.com
MACmetalarchitectural.com