



Trims & Moldings

SIDING

5975 chemin de la Savane, Saint-Hubert, QC J3Y 0X1
T. 450 464-5486 | F. 450 464-4538
MACmetalarchitectural.com
info@macmetalarchitectural.com

MAC
METAL ARCHITECTURAL

2023

Disposition of the moldings

The suggested dispositions will apply to all profiles

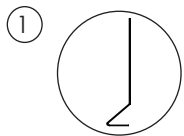

1 Starter strip

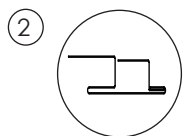

2 Vertical transition trim

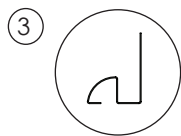

3 Inside corner or QJ

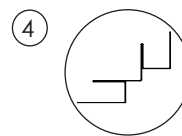

4 Outside corner

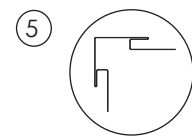

5 Outside corner with integrated J

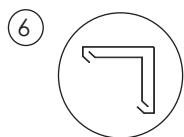

6 Outside corner



7 Horizontal transition trim

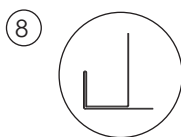

8 Extended J trim

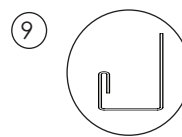

9 J trim

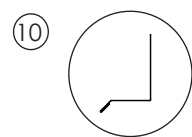

10 Drip flashing

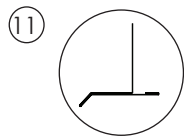

11 Extended drip flashing

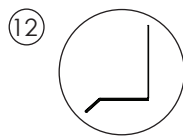

12 Double drip flashing

Approximate manufacturing tolerances :
 1/16" on all lengths
 1 degree on bend angles

Harrywood PLUS, Harrywood, Harrywood Block, MS 14, Norwood & Norwood Mini Profiles

Variable = Degree or inch / mm Units = Inch and/or mm

All Trims come in a 10' length, 26 gauge

Starting strip

The starting strip will be the first to be put in place at the beginning of the work to guide and secure the production of the project.

No. M10SHWP (HWP) Starting strip

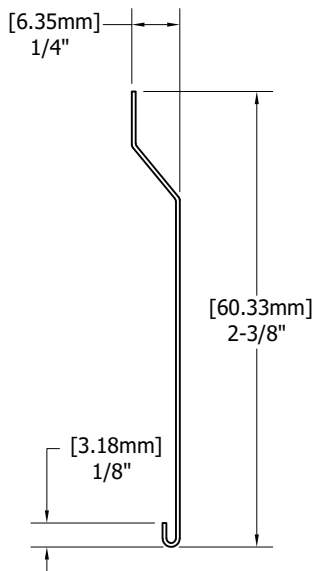

No. M10SHW (HW & HWB) Starting strip

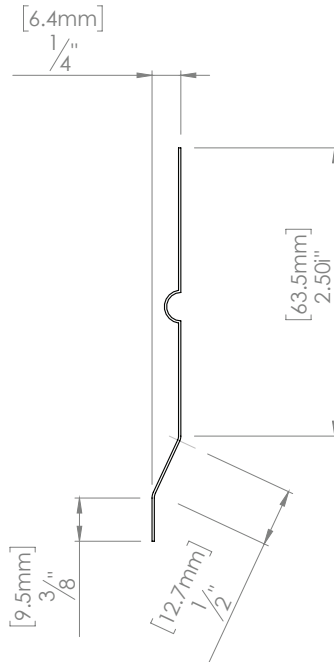

No. M10S14 (MS14) Starting strip

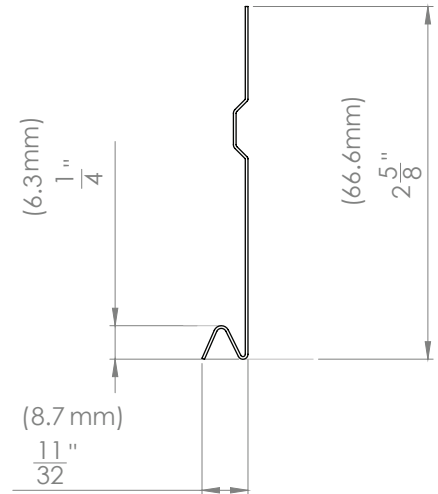

No. M10D (NW & NWM) Starting strip

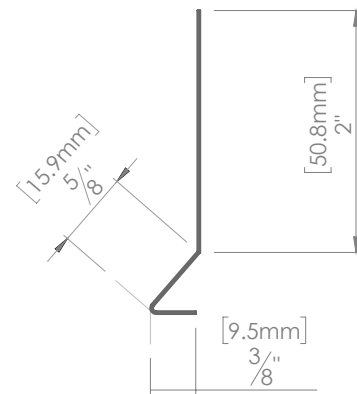

Rear restraining bracket

The rear support bracket acts as a reinforcement support when installing on large surfaces.

No. ABRA2 (HW) Rear restraining bracket

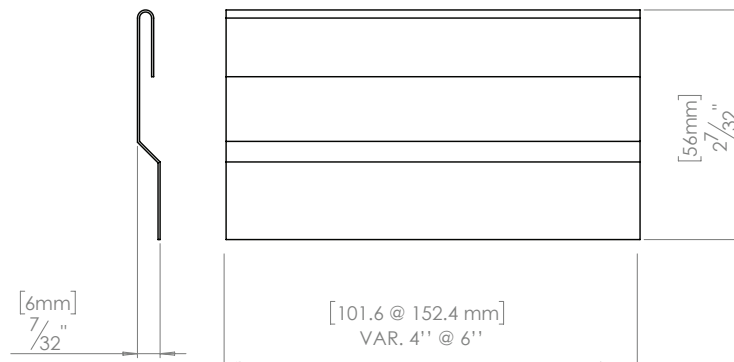

Harrywood PLUS, Harrywood, Harrywood Block, MS 14, Norwood & Norwood Mini Profiles

Variable = Degree or inch / mm Units = Inch and/or mm

All Trims come in a 10' length, 26 gauge

J trim

The J trim is used on the sides and bottom of any opening. Available in several forms depending on the needs of the project:

The double J trim will be used when a stronger molding is required or to fill a spacing. Note that the entire piece is colored.

The extended J trim will be used to cover more surface as in the case of a window that is coming out of the wall.

No. M01C (HWP, HW, HWB & MS14)

J trim

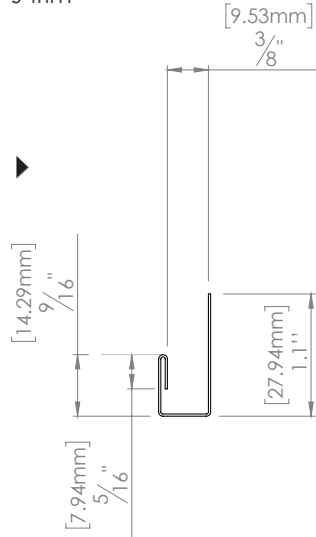

No. M01D (NW & NWM)

J trim

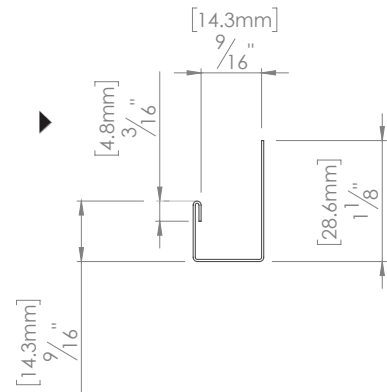

No. M03C (HWP, HW, HWB & MS 14)

Extended J trim

(2 pieces)

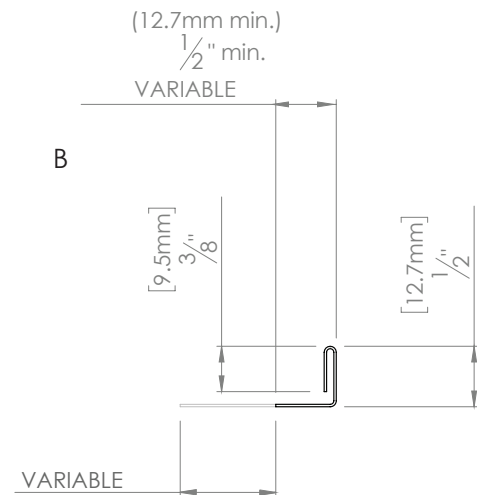
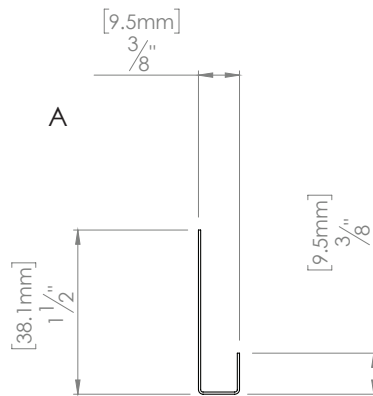
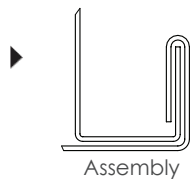

No. M03D (NW & NWM)

Extended J trim

(2 pieces)

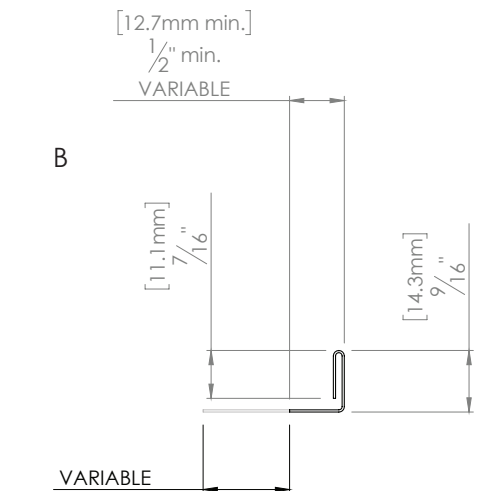
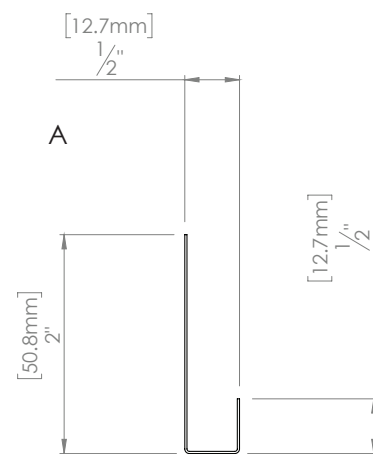
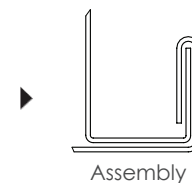

Harrywood PLUS, Harrywood, Harrywood Block, MS 14, Norwood & Norwood Mini Profiles

Variable = Degree or inch / mm Units = Inch and/or mm

All Trims come in a 10' length, 26 gauge

Inside corner or QJ

The QJ molding has the same functions as the J trim but is used most frequently as an interior corner.

No. M22C (HWP, HW, HWB & MS14)
Inside corner or QJ

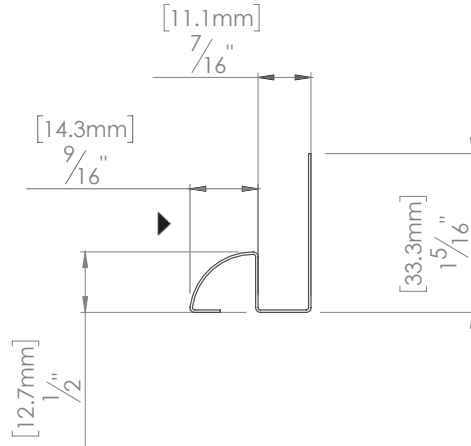

No. M22D (NW & NWM)
Inside corner or QJ

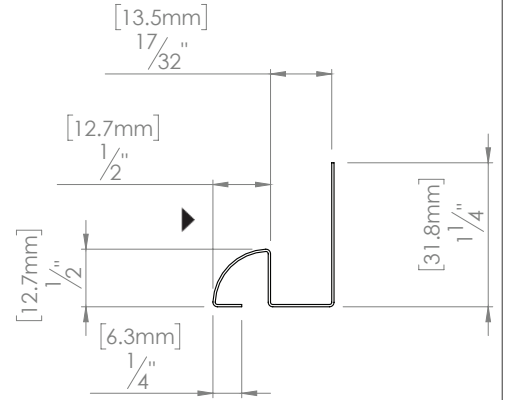

Drip flashing

It is important to use a drip flashing over any opening to drain water.

The double drip flashing will be used to fill a gap. Note that the entire piece is colored.

The extended drip flashing is chosen when a window or opening is too far towards the inside of the wall. Note that the entire piece is colored.

No. M50CD (HWP, HW, HWB, MS14, NW & NWM)
Flashing drip

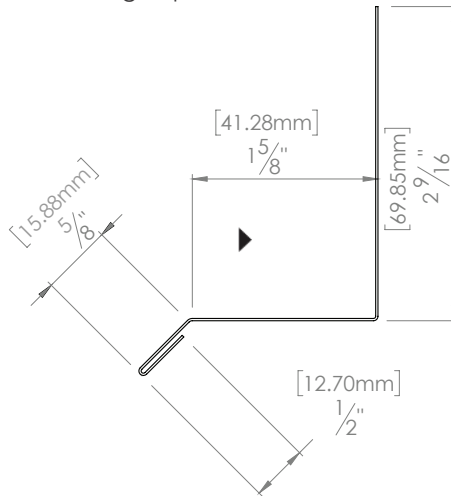

No. M53CD (HWP, HW, HWB, MS14, NW & NWM)
Double flashing drip

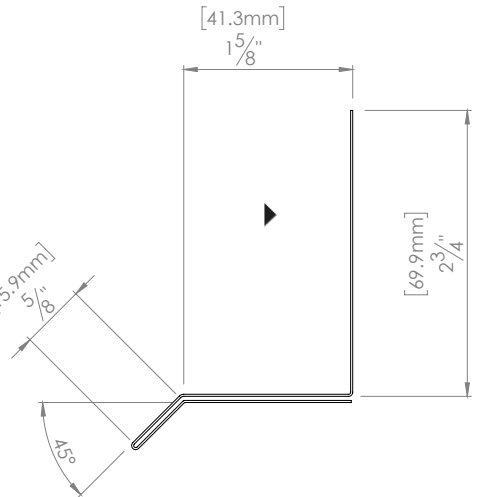

No. M56CD (HWP, HW, HWB, MS14, NW & NWM)
Extended drip flashing w/variable

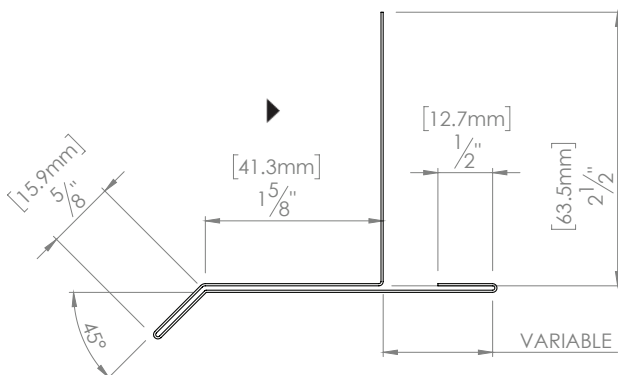

No. M52CD (HWP, HW, HWB, MS14, NW & NWM)
Flashing drip variable

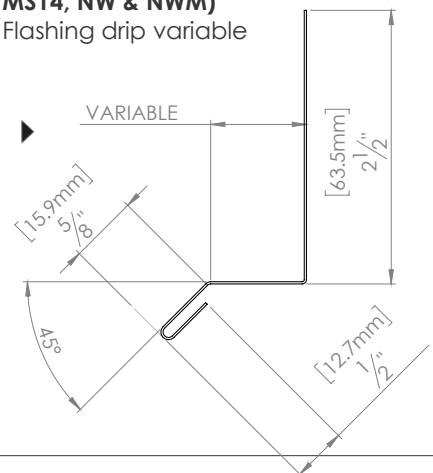

Harrywood PLUS, Harrywood, Harrywood Block, MS 14, Norwood & Norwood Mini Profiles

Variable = Degree or inch / mm Units = Inch and/or mm

All Trims come in a 10' length, 26 gauge

Outside corner

The outside corner is used to cover the junction of two outgoing walls.

No. M20D (NW & NWM)

Outside corner with integrated J trim

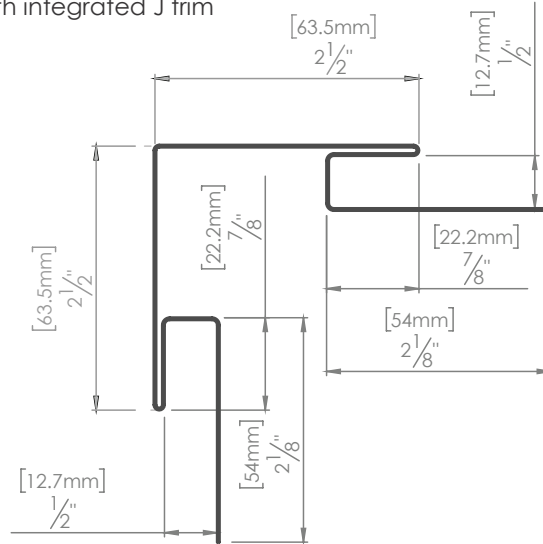

No. M20C (HWP, HW, HWB & MS14)

Outside corner (2 pieces)

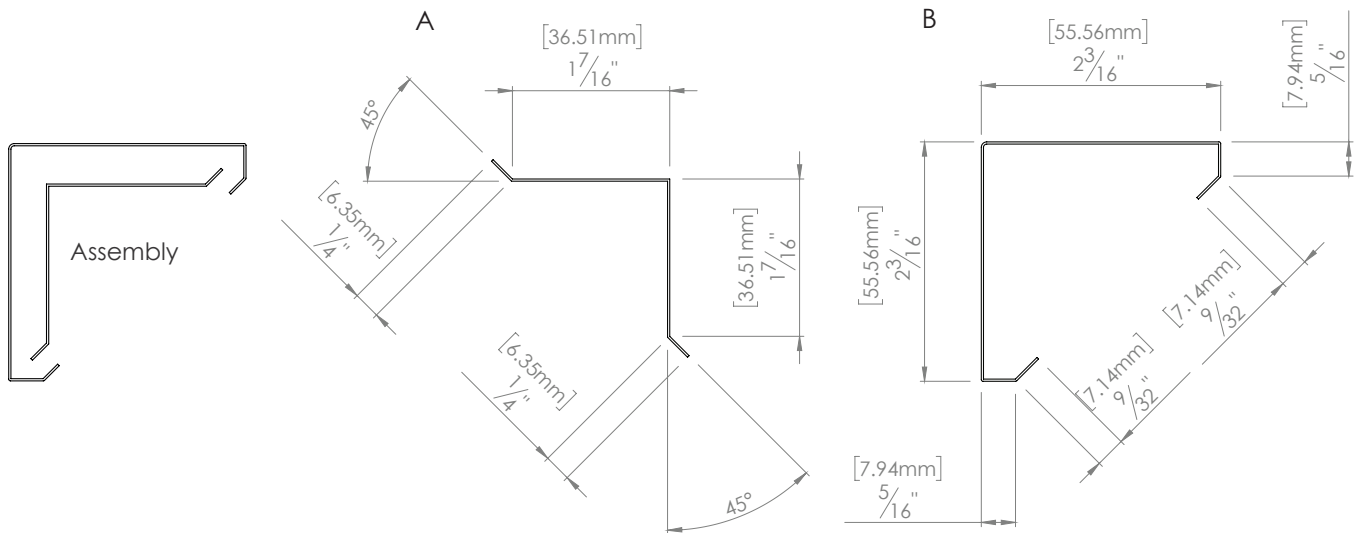

Harrywood PLUS, Harrywood, Harrywood Block, MS 14, Norwood & Norwood Mini Profiles

Variable = Degree or inch / mm Units = Inch and/or mm

All Trims come in a 10' length, 26 gauge

Transition trim

Used to create a transition between two sidings, to create a junction during the installation of a large surface of the same siding, or to mark the change between two materials.

The horizontal transition molding can also be used as a floor slump.

No. M12C (HWP, HW, HWB & MS14)

Vertical transition trim (2 pieces)

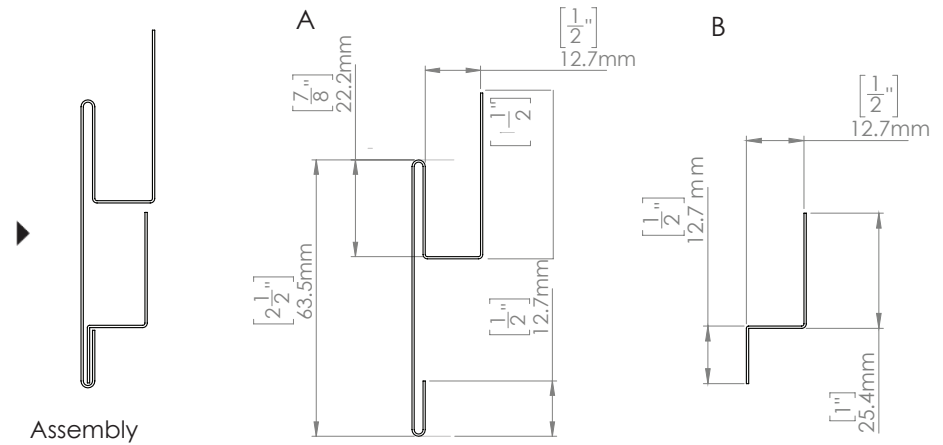

No. M13C (HWP, HW, HWB & MS14)

Horizontal transition trim (2 pieces)

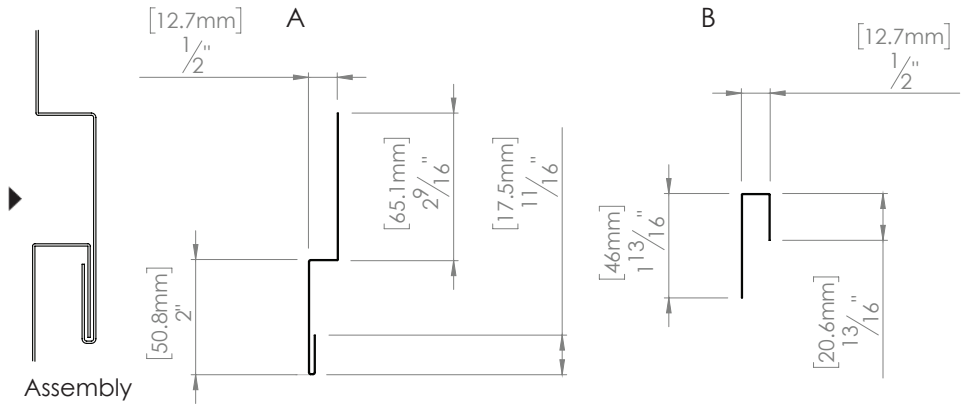

No. M13D (NW & NWM)

Horizontal transition trim (2 pieces)

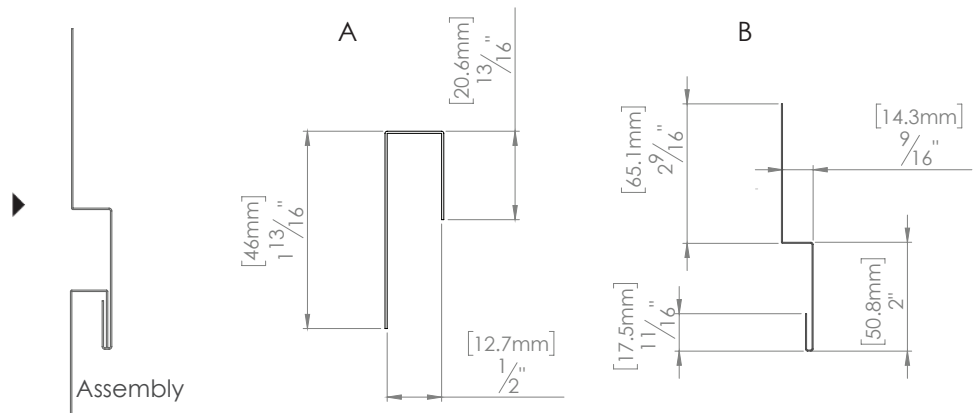

Harrywood PLUS, Harrywood, Harrywood Block, MS 14, Norwood & Norwood Mini Profiles

Variable = Degree or inch / mm Units = Inch and/or mm

All Trims come in a 10' length, 26 gauge

Transition trim

Used to create a transition between two sidings, to create a junction during the installation of a large surface of the same siding, or to mark the change between two materials.

The horizontal transition molding can also be used as a floor slump.

No. M12D (NW & NWM) Vertical transition trim (2 pieces)

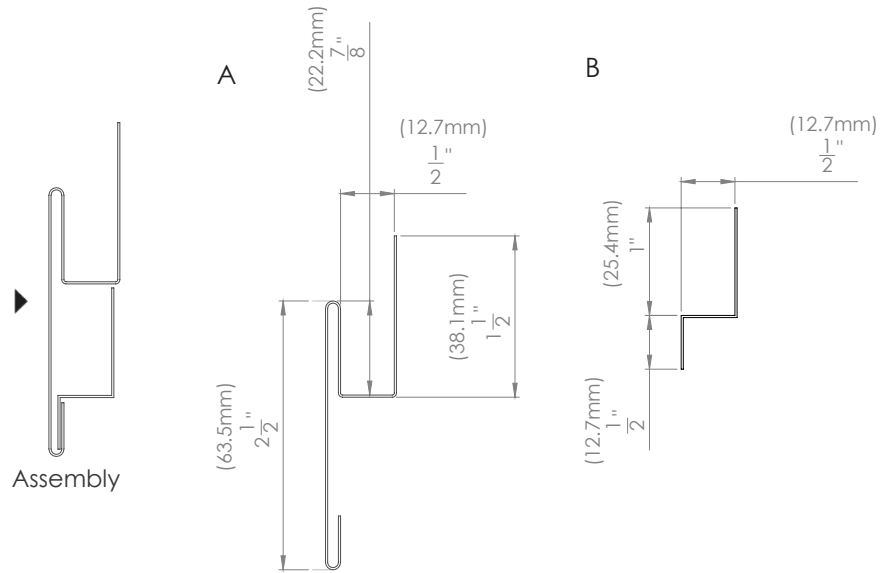

L trim

The L trim will be used to fill a gap or to create a transition space between two sidings.

No. M14CD (HWP, HW, HWB, MS14, NW & NWM) L trim

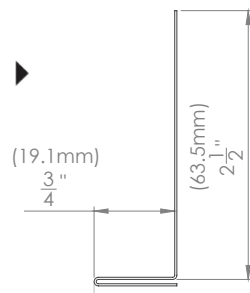

Polymac, Versa & Metal Block Profiles

Variable = Degree or inch / mm Units = Inch and/or mm

All Trims come in a 10' length, 26 gauge

Starting strip

The starting strip will be the first to be put in place at the beginning of the work to guide and secure the production of the project.

No. M10G (POL, VS, MB)
Starting strip

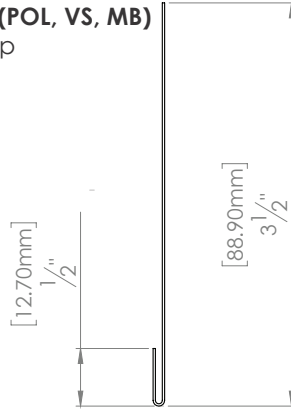

J trim

The J trim is used on the sides and bottom of any opening. Available in several forms depending on the needs of the project:

The double J trim will be used when a stronger molding is required or to fill a spacing. Note that the entire piece is colored.

The Extended J trim will be used to cover more surface as in the case of a window that is coming out of the wall.

No. M01G (POL, VS, MB)
J trim

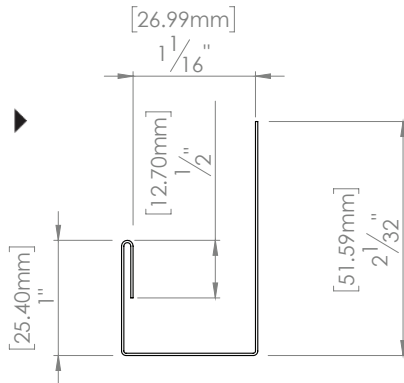

No. M03G (POL, VS, MB)
Extended J trim variable

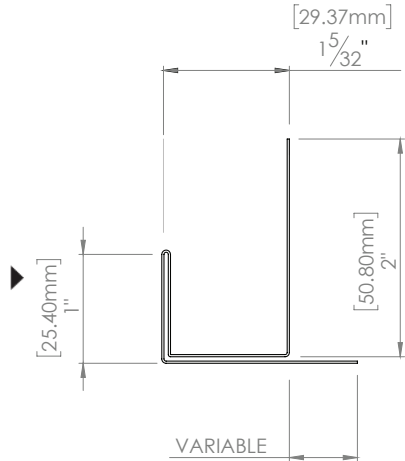

Inside corner

The inside corner is used at the junction of two incoming walls.

No. M22G (POL, VS, MB)
Inside corner

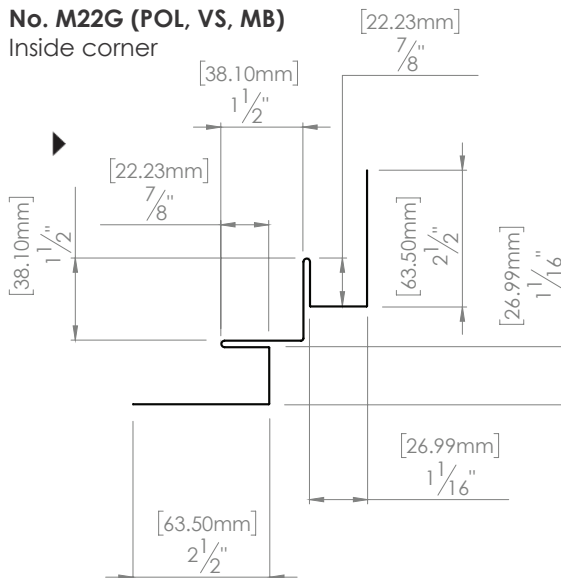

Polymac, Versa & Metal Block Profiles

Variable = Degree or inch / mm Units = Inch and/or mm

All Trims come in a 10' length, 26 gauge

Outside corner

The outside corner is used to cover the junction of two outgoing walls.

No. M21G (POL, VS, MB)

Outside corner w/ integrated J Trim

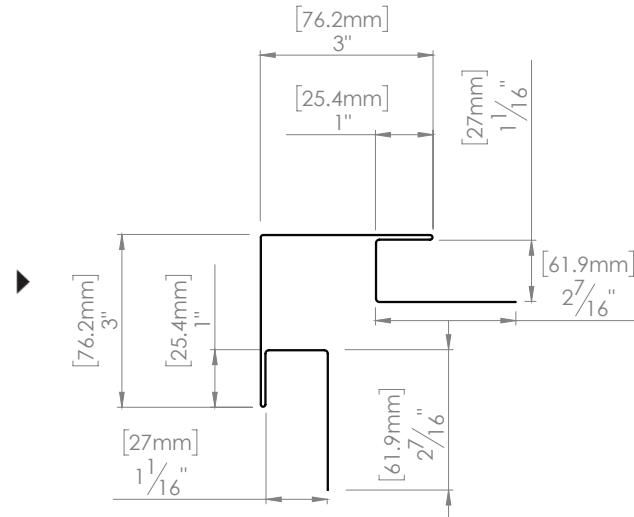

No. M20G (POL, VS, MB)

Outside corner (2 pieces)

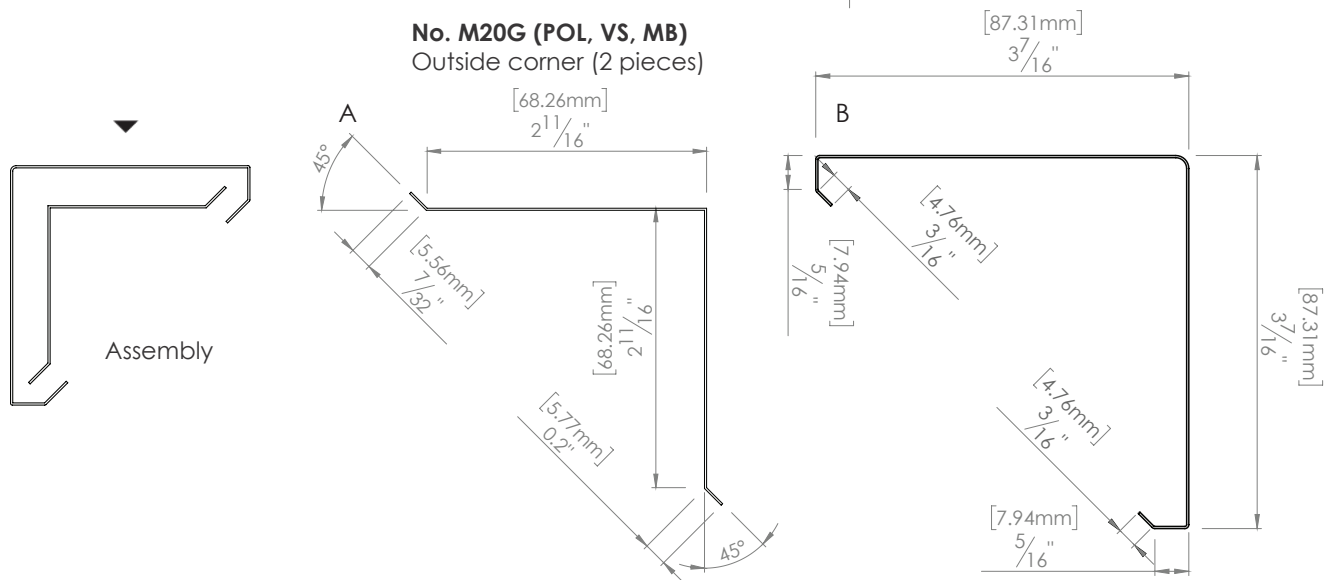

L trim

The L trim will be used to fill a gap or to create a transition space between two sidings.

No. M14G (POL, VS, MB)

L trim

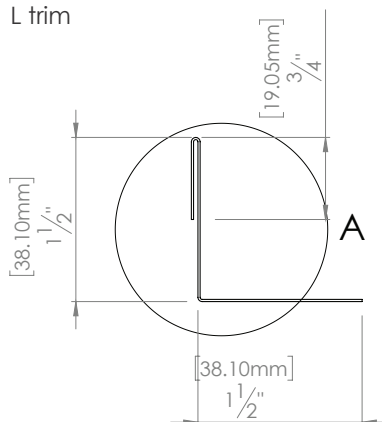

Polymac, Versa & Metal Block Profiles

Variable = Degree or inch / mm Units = Inch and/or mm

All Trims come in a 10' length, 26 gauge

Drip flashing

It is important to use a drip flashing over any opening to drain water.

The double drip flashing will be used to fill a gap. Note that the entire piece is colored.

The extended drip flashing is chosen when a window or opening is too far towards the inside of the wall. Note that the entire piece is colored.

No. M50G (POL, VS, MB)
Drip flashing

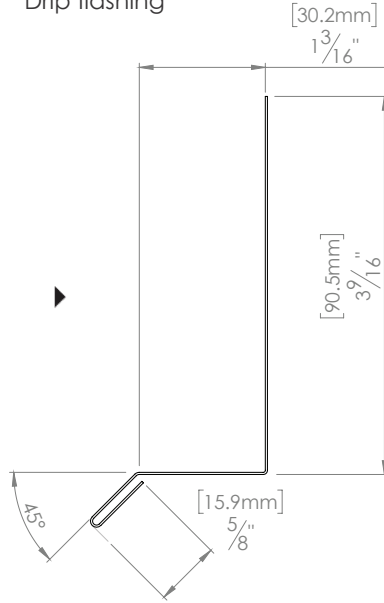

No. M51G (POL, VS, MB)
Drip flashing w/ 90 degree angle

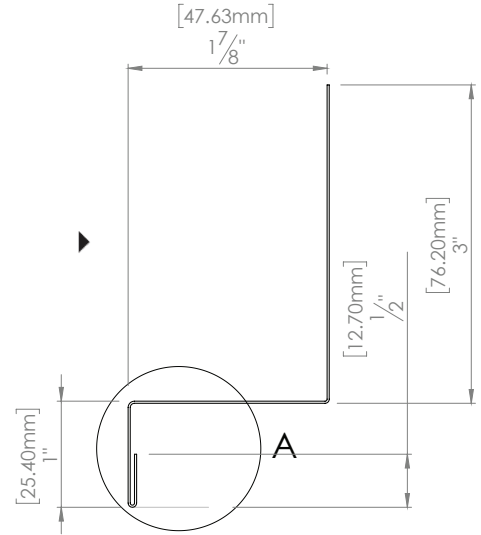

No. M52G (POL, VS, MB)
Drip flashing variable

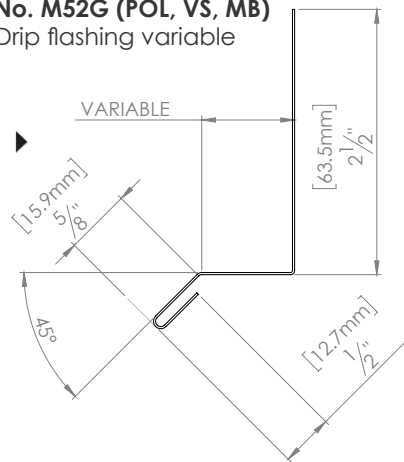

No. M53G (POL, VS, MB)
Double drip flashing

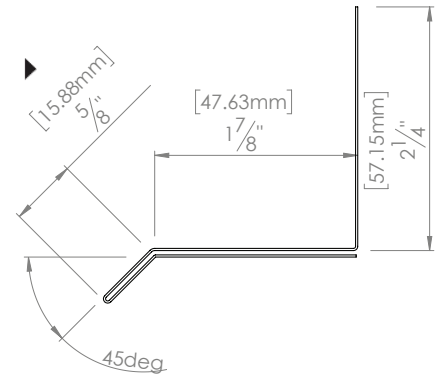

No. M56G (POL, VS, MB)
Extended drip flashing w/ variable

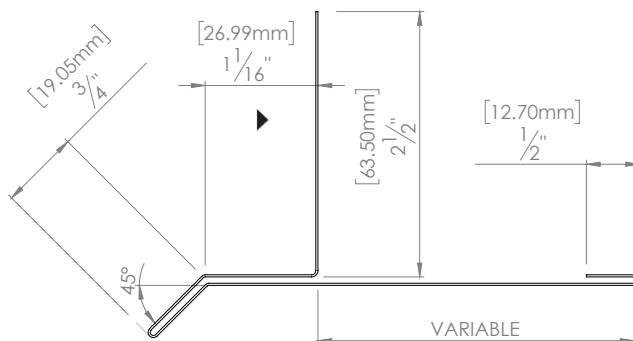

No. M55G (POL, VS, MB)
Drip flashing double variable

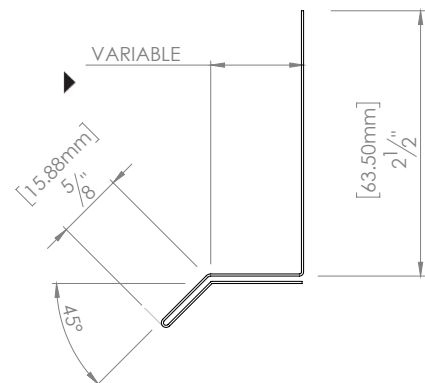

Polymac, Versa & Metal Block Profiles

Variable = Degree or inch / mm Units = Inch and/or mm

All Trims come in a 10' length, 26 gauge

T trim

We recommend installing T molding every 10 to 12 feet when installing the Versa profile.

No. M11G (POL, VS, MB)
T trim

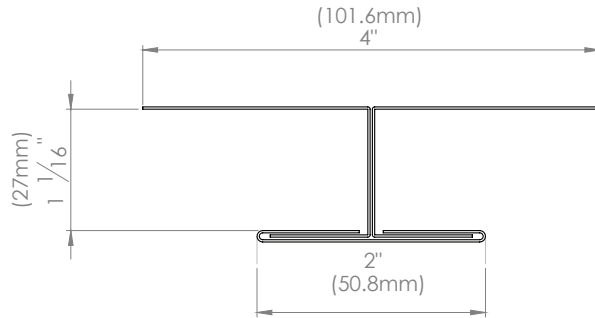

S trim clip

The S molding is recommended for horizontal installations; it acts as a bridging joint.

No. M16G (POL, VS, MB)
S trim clip

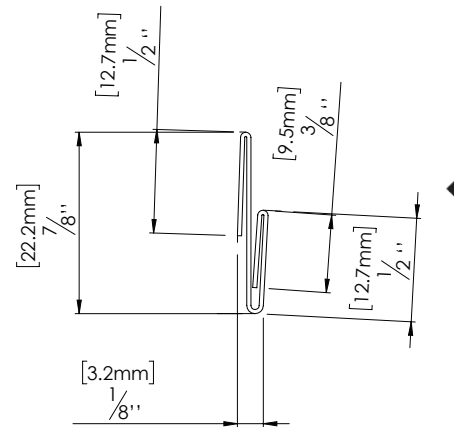

Polymac Profile

Variable = Degree or inch / mm Units = Inch and/or mm

All Trims come in a 10' length, 26 gauge

U trim or fixation trim

The U-shaped molding is the fastening molding designed for the installation of Polymac panels. It acts as a fixing support during the pre-installation of the panels.

No. M15P (POL)

U trim or fixation trim

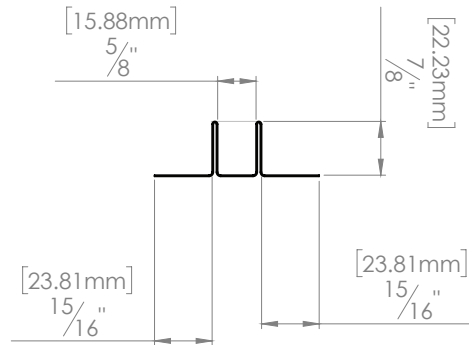

W Trim Outside Corner

The outside corner is used to cover the junction of two outgoing walls.

No. MXXP (POL)

W Trim Outside Corner

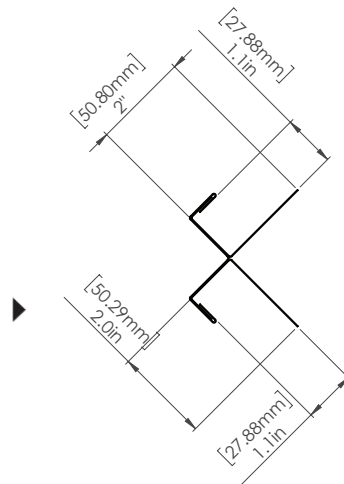

J Trim (Polymac)

The J trim is used on the sides and bottom of any opening. Available in several forms depending on the needs of the project:

The double J trim will be used when a stronger molding is required or to fill a spacing. Note that the entire piece is colored.

The Extended J trim will be used to cover more surface as in the case of a window that is coming out of the wall.

No. M01P (POL)

Finition J Trim

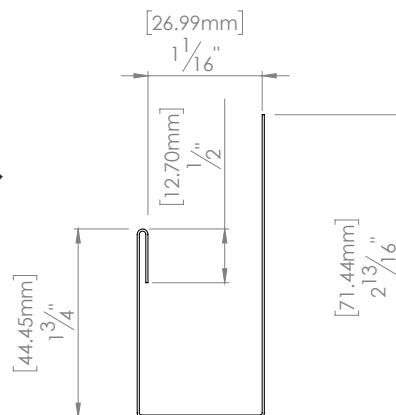

MS 380 Corrugated Profiles

Variable = Degree or inch / mm Units = Inch and/or mm

All Trims come in a 10' length, 26 gauge

J Trim

No. M01F (MS380)

J trim

The J trim is used on the sides and bottom of any opening. Available in several forms depending on the needs of the project:

The Double J Trim will be used when a stronger molding is required or to fill a spacing. Note that the entire piece is colored.

The Extended J Trim will be used to cover more surface as in the case of a window that is coming out of the wall.

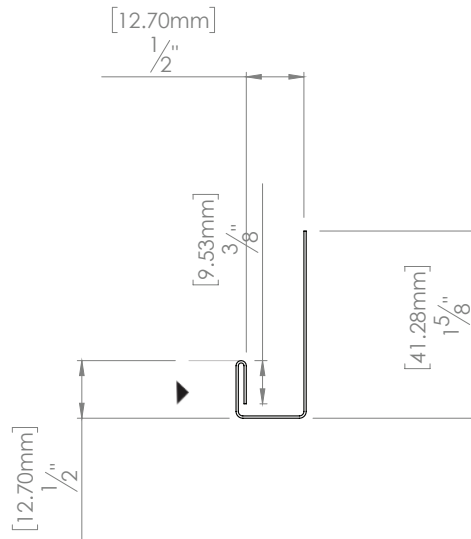

No. M03F (MS380)

Extended J-trim variable (2 pieces)

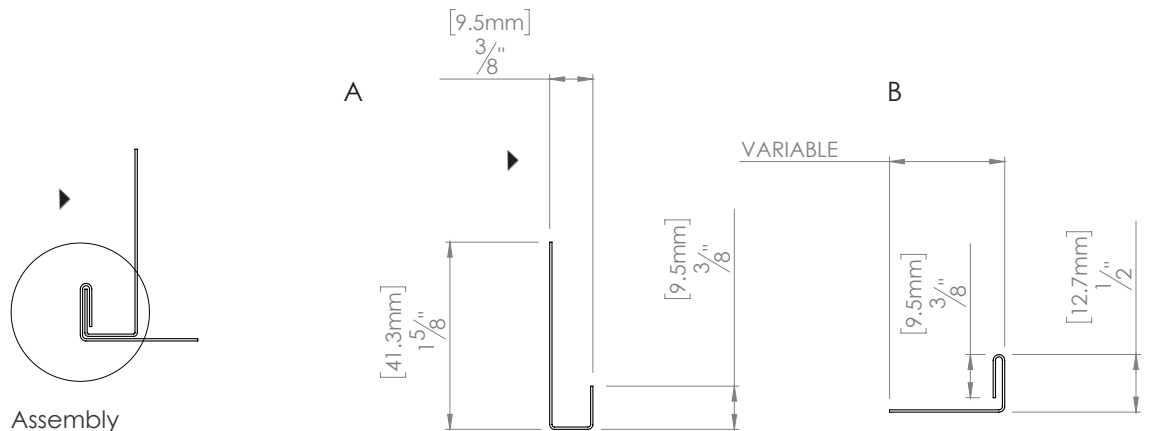

MS 380 Corrugated Profiles

Variable = Degree or inch / mm Units = Inch and/or mm

All Trims come in a 10' length, 26 gauge

Outside corner

The outside corner is used to cover the junction of two outgoing walls.

No. M21F (MS380)

Outside corner w/ integrated J Trim

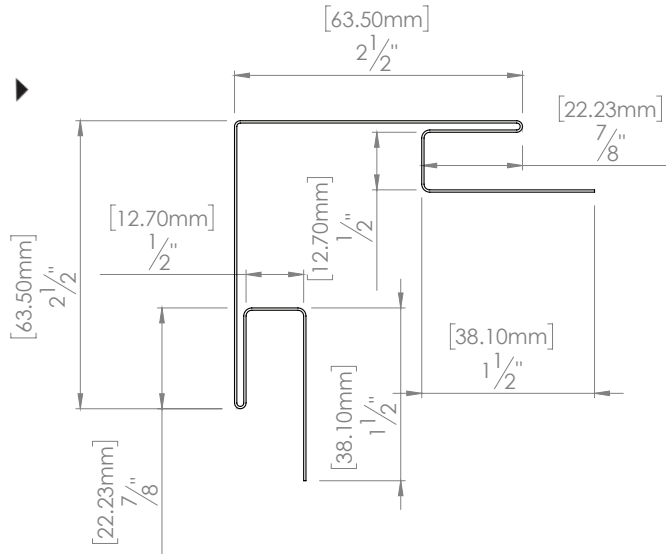

Inside corner

The inside corner is used at the junction of two incoming walls.

No. M22F (MS380)

Inside corner

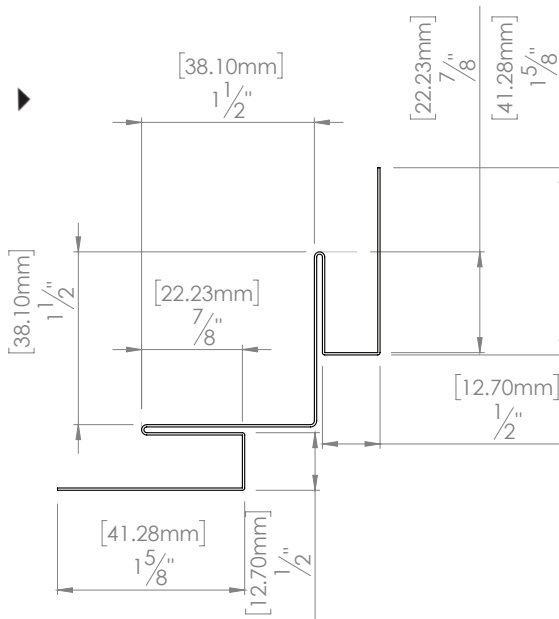

MS 380 Corrugated Profiles

Variable = Degree or inch / mm Units = Inch and/or mm

All Trims come in a 10' length, 26 gauge

Drip flashing

It is important to use a drip flashing over any opening to drain water.

The double drip flashing will be used to fill a gap. Note that the entire piece is colored.

The extended drip flashing is chosen when a window or opening is too far towards the inside of the wall. Note that the entire piece is colored.

No. M50F (MS380)

Drip flashing

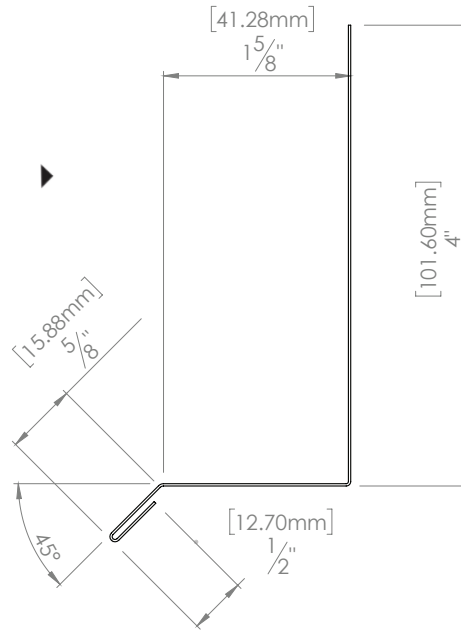

No. M56F (MS380)

Extended drip flashing w/ variable

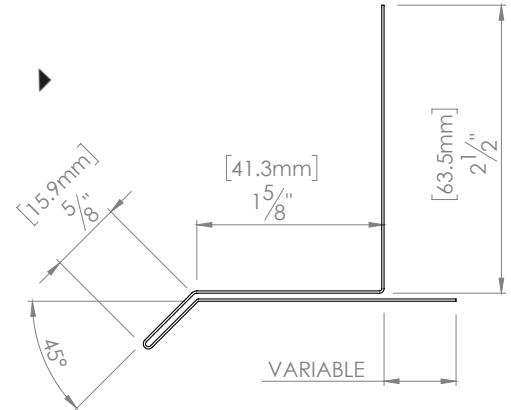

No. M53F (MS380)

Double drip flashing

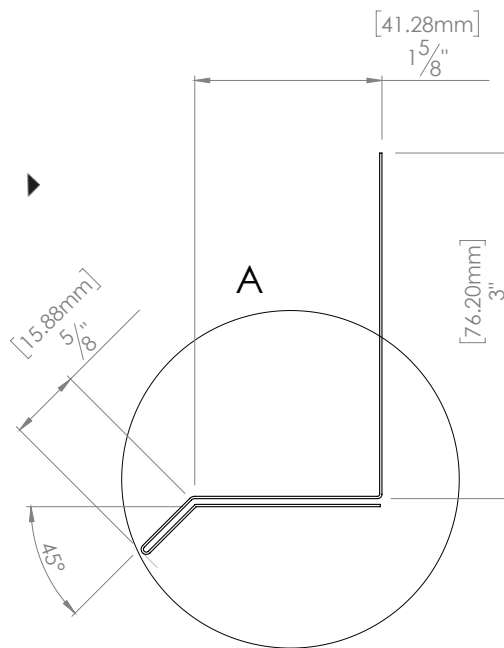

MS 750 & MS 750 I Profiles

Variable = Degree or inch / mm Units = Inch and/or mm

All Trims come in a 10' length, 26 gauge

J Trim

The J trim is used on the sides and bottom of any opening. Available in several forms depending on the needs of the project:

The Double J Trim will be used when a stronger molding is required or to fill a spacing. Note that the entire piece is colored.

The Extended J Trim will be used to cover more surface as in the case of a window that is coming out of the wall.

No. M01E (MS750 & 750I)

J Trim

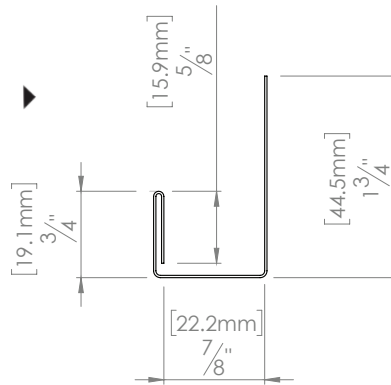

No. M03E (MS750 & 750I)

Extended J Trim w/variable

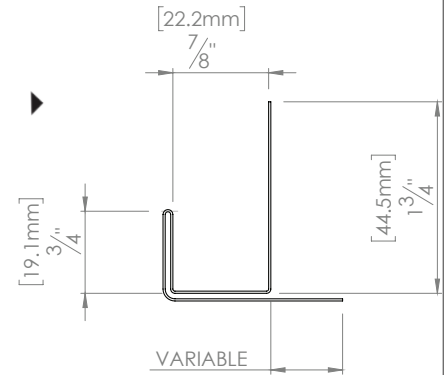

Outside corner

The outside corner is used to cover the junction of two outgoing walls.

No. M21E (MS750 & 750I)

Outside corner w/ integrated J Trim

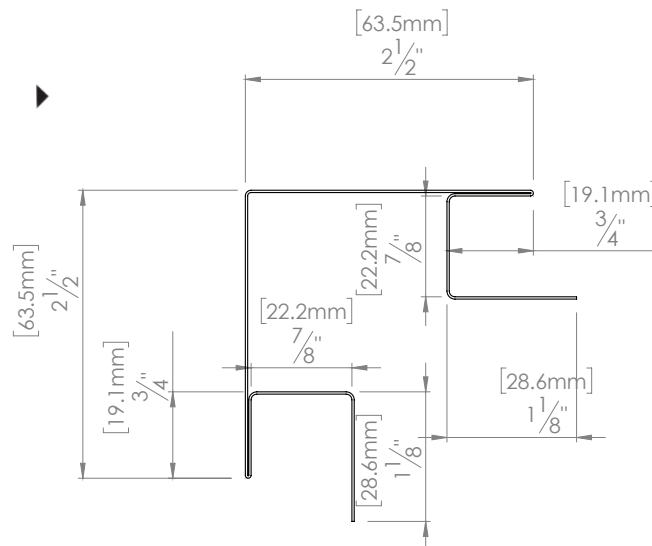

MS 750 & MS 750 I Profiles

Variable = Degree or inch / mm Units = Inch and/or mm

All Trims come in a 10' length, 26 gauge

Inside corner

The inside corner is used at the junction of two incoming walls

No. M22E (MS750 & 750I)
Inside corner

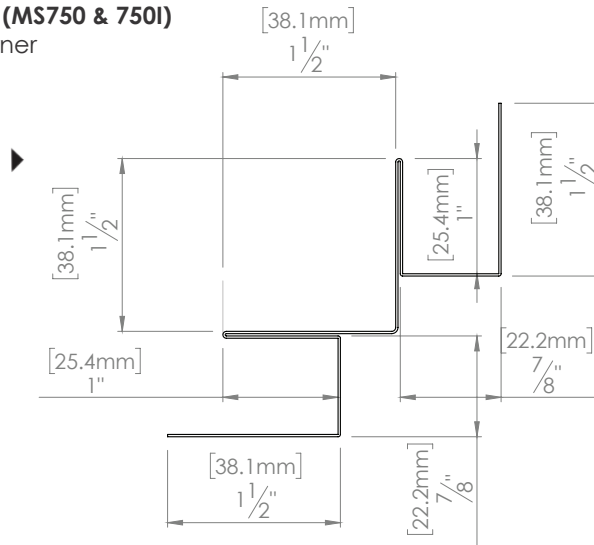

Drip flashing

It is important to use a drip flashing over any opening to drain water.

The double drip flashing will be used to fill a gap. Note that the entire piece is colored.

The extended drip flashing is chosen when a window or opening is too far towards the inside of the wall. Note that the entire piece is colored.

No. M50E (MS750 & 750I)
Drip flashing

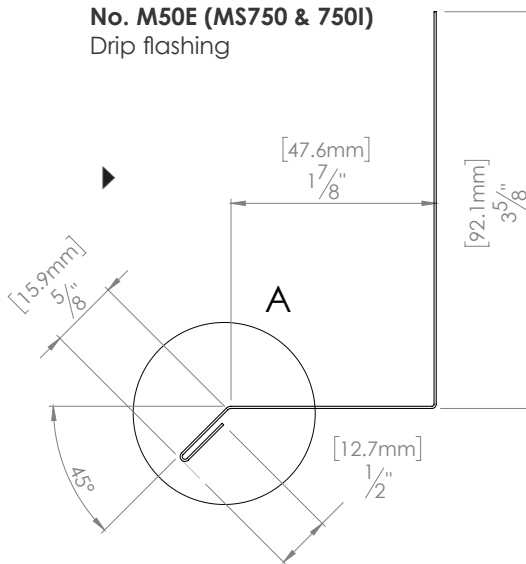

No. M53E (MS750 & 750I)
Double drip flashing

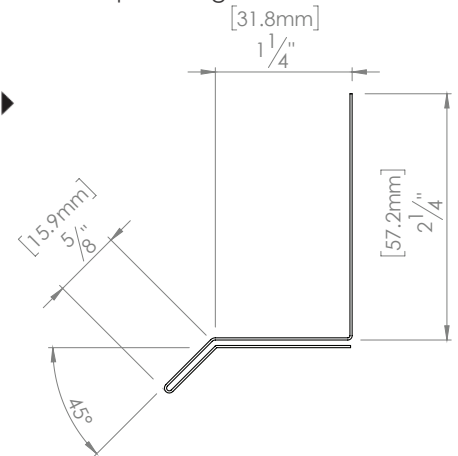

No. M56E (MS750 & 750I)
Extended drip flashing w/ variable

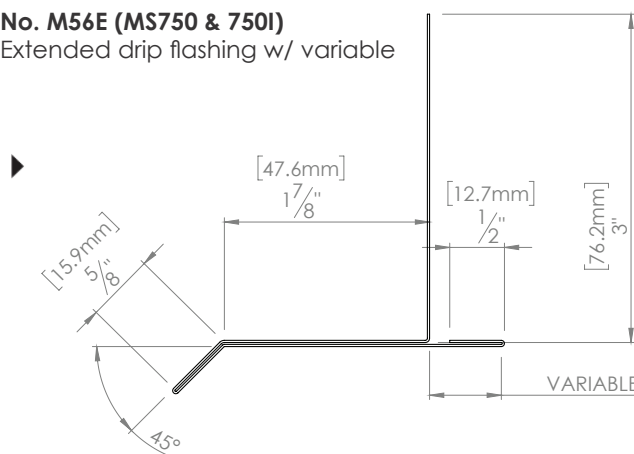

Board & Batten & Reverse Board & Batten Profiles

Variable = Degree or inch / mm Units = Inch and/or mm

All Trims come in a 10' length, 26 gauge

Starting strip

The starting strip will be the first to be put in place at the beginning of the work to guide and secure the production of the project.

No. M17H (BB & RBB)

Bricks transition trim / Starter strip 3'' (2 parts)

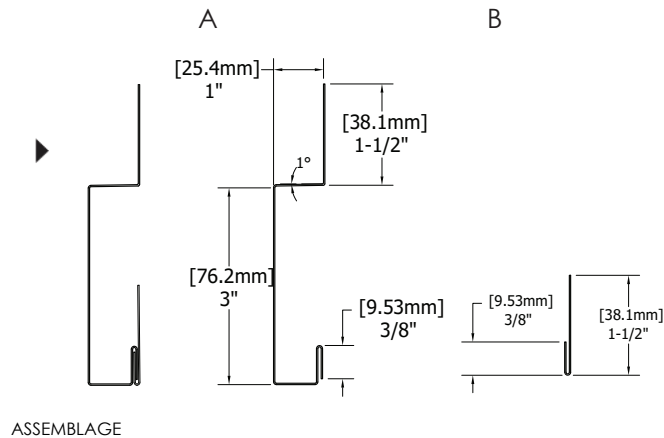

Batten trim filler

The finishing strip acts as a filler inside the molding. Ideal when the "batten" of the sheets do not end inside a molding. They will then come to fill the gap by giving the impression of a batten for a perfect finish.

No. M06H (BB & RBB)

Batten trim filler

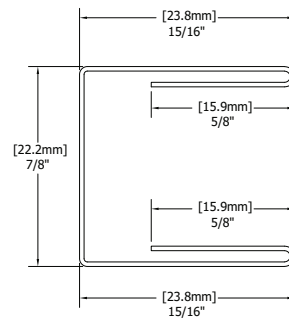

Board & Batten & Reverse Board & Batten Profiles

Variable = Degree or inch / mm Units = Inch and/or mm

All Trims come in a 10' length, 26 gauge

J Trim

The J trim is used on the sides and bottom of any opening. Available in several forms depending on the needs of the project:

The Double J Trim will be used when a stronger molding is required or to fill a spacing. Note that the entire piece is colored.

The Extended J Trim will be used to cover more surface as in the case of a window that is coming out of the wall.

No. M01H (BB & RBB)
J trim 1 in

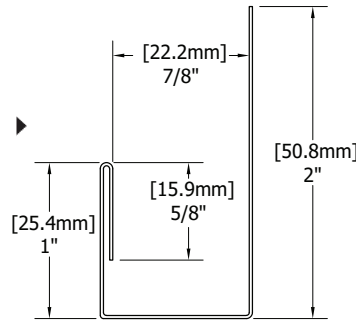

No. M03H (BB & RBB)
Extended J Trim 1 in w/var

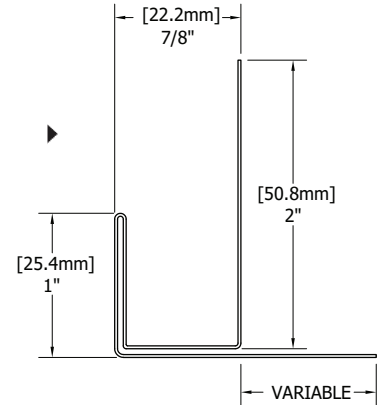

No. M02H (BB & RBB)
Double J trim 1 in

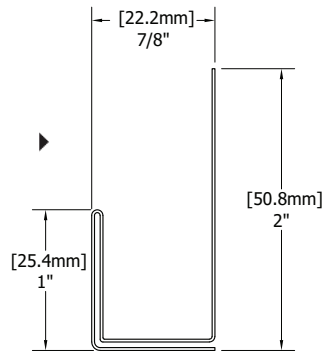

No. M05H (BB & RBB)
Extended J Trim 3 in w/var

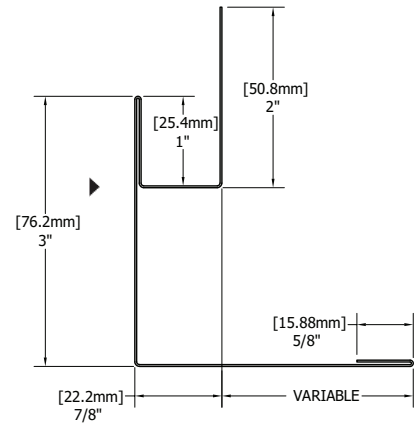

No. M04H (BB & RBB)
J trim 3 in (2 pieces)

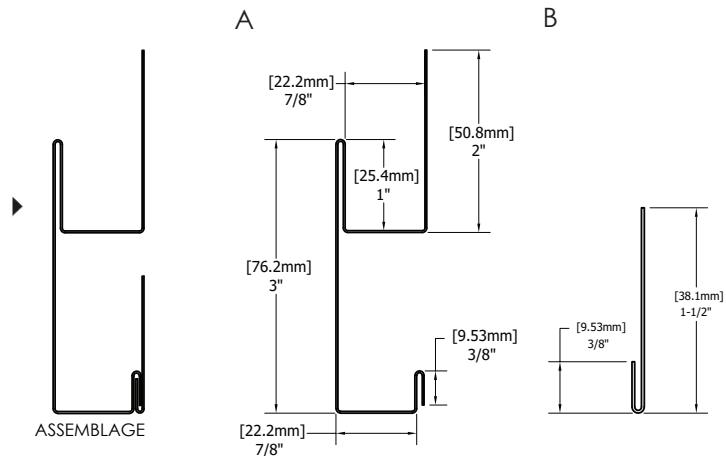

Board & Batten & Reverse Board & Batten Profiles

Variable = Degree or inch / mm Units = Inch and/or mm

All Trims come in a 10' length, 26 gauge

Drip flashing

It is important to use a drip flashing over any opening to drain water.

The double drip flashing will be used to fill a gap. Note that the entire piece is colored.

The extended drip flashing is chosen when a window or opening is too far towards the inside of the wall. Note that the entire piece is colored.

No. M51H.A (BB & RBB)

Drip flashing w/90° angle

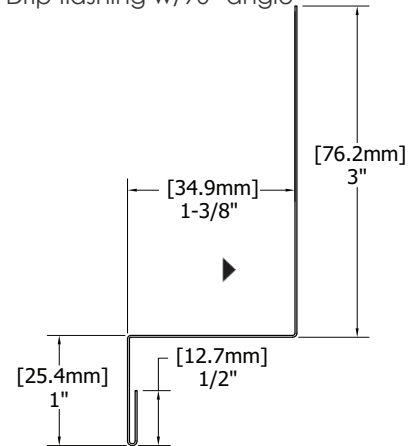

No. M53H.A (BB & RBB)

Double drip flashing

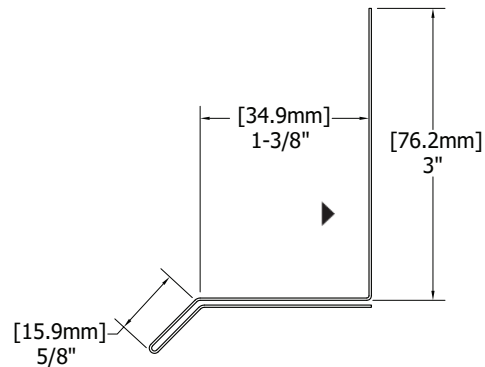

No. M50H.A (BB & RBB)

Drip flashing

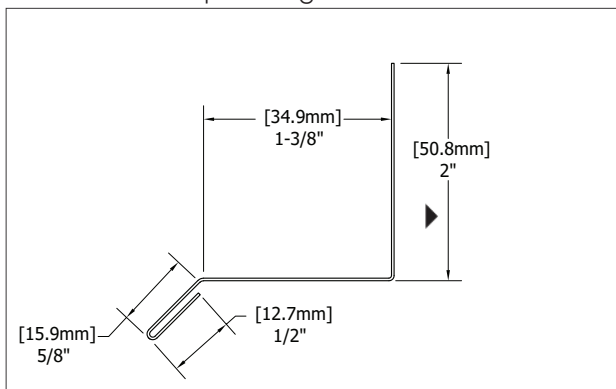

No. M54H.A (BB & RBB)

Double drip flashing w/90 degrees angle

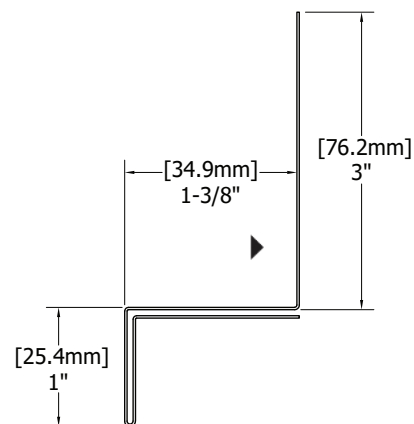

Board & Batten & Reverse Board & Batten Profiles

Variable = Degree or inch / mm Units = Inch and/or mm

All Trims come in a 10' length, 26 gauge

Drip flashing

It is important to use a drip flashing over any opening to drain water.

The double drip flashing will be used to fill a gap. Note that the entire piece is colored.

The extended drip flashing is chosen when a window or opening is too far towards the inside of the wall. Note that the entire piece is colored.

No. M56H.A (BB & RBB) Extended drip flashing w/var

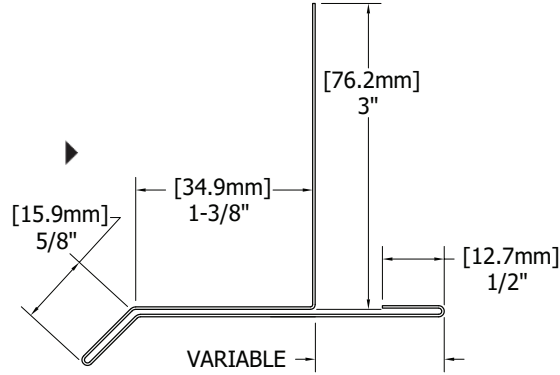

No. M57H.A (BB & RBB) Extended drip flashing w/90° angle

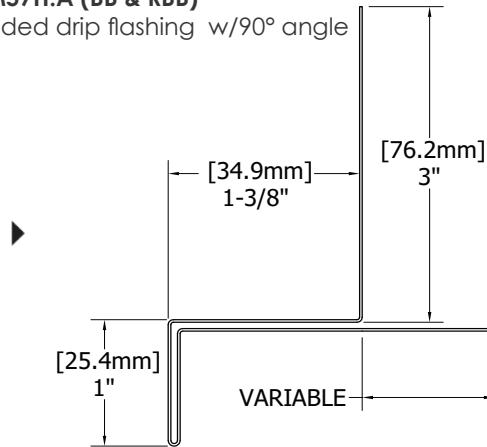

Transition trim

Used to create a transition between two sidings, to create a junction during the installation of a large surface of the same siding, or to mark the change between two materials.

The horizontal transition molding can also be used as a floor slump.

No. M17H (BB & RBB) Bricks transition trim / Starter strip 3'' (2 parts)

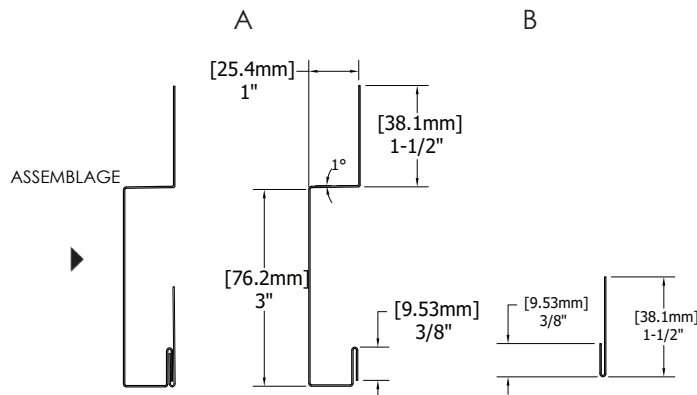

Board & Batten & Reverse Board & Batten Profiles

Variable = Degree or inch / mm Units = Inch and/or mm

All Trims come in a 10' length, 26 gauge

Transition trim

Used to create a transition between two sidings, to create a junction during the installation of a large surface of the same siding, or to mark the change between two materials.

The horizontal transition molding can also be used as a floor slump.

No. M12H (BB & RBB)

Vertical transition trim (2 pieces)

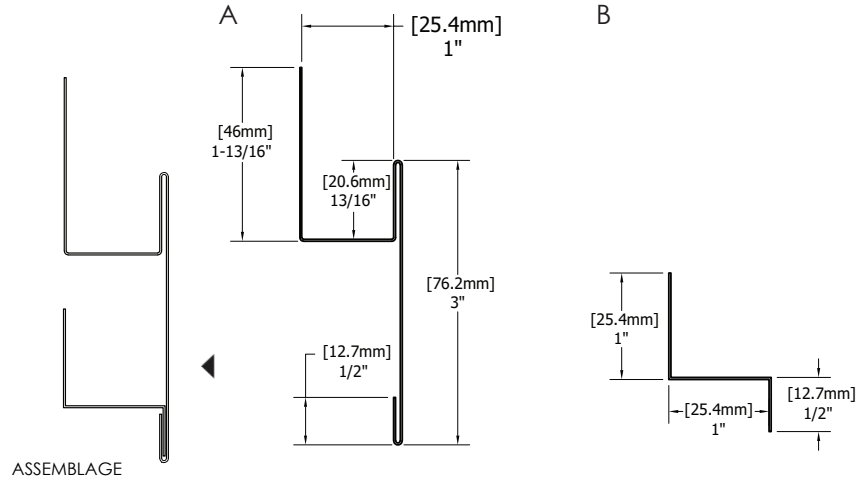

No. M13H (BB & RBB)

Horizontal transition trim (2 pieces)

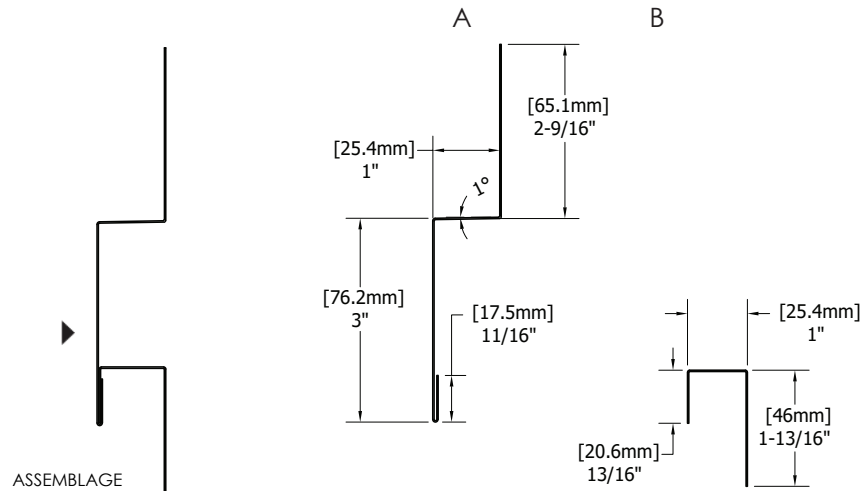

Board & Batten & Reverse Board & Batten Profiles

Variable = Degree or inch / mm Units = Inch and/or mm

All Trims come in a 10' length, 26 gauge

Inside corner

No. M22H (BB & RBB) Inside Corner

The inside corner is used at the junction of two incoming walls.

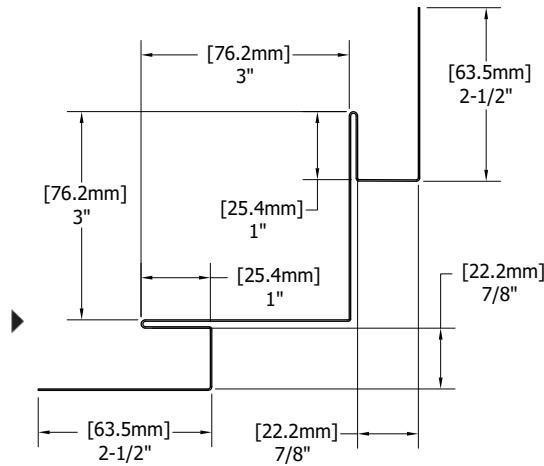

Outside corner

No. M21H (BB & RBB) Outside corner w/ integrated J Trim

The outside corner is used to cover the junction of two outgoing walls.

